

**RRJ-95 AIRCRAFT MAINTENANCE MANUAL**
**SLAT SECTION 4 — INSPECTION/CHECK**

\*\*\*Paras 2, 4B(1): CORRECTION/ADDITION/AMPLIFICATION

\*\*\*Paras 5A(2), 5A(3): TEXT CORRECTIONS

\*\*\*Figure 602: CHANGED

**TASK 57-45-00-220-802**
**Detailed Inspection of the Slat Section 4 Tracks 8 and 9**

 1. Reason for Job

Refer to the MPD Task: 574000ST-04

 2. Logistics

## A. References

<u>Task</u>	<u>Title</u>
<b>24-00-00-860-801</b>	Opening and Closing of the Circuit Breakers
<b>27-50-00-860-801</b>	Extension of the Flaps and Slats on the Ground
<b>27-50-00-860-802</b>	Retraction of the Flaps and Slats on the Ground
<b>57-00-00-920-801</b>	Wings Maintenance and Safety Precautions
<b>SRM</b>	Structure Repair Manual

## B. Tools and Ground Support Equipment

<u>Designation</u>	<u>Description</u>	<u>Quantity</u>
<b>KI-20-002</b>	Standard Aircraft Periodic Maintenance Tool Set	1
<b>GE-06-002</b>	Wing and Fuselage Platform	1
No specific	5x magnifier	1
No specific	Flashlight	1
No specific	Set of feelers	1
No specific	Maetal ruler 100 mm (3.93 in)	1
No specific	Varnier calliper	1
No specific	Warning tag	1

## C. Ingredients and Consumable Products

<u>Designation</u>	<u>Description</u>	<u>Quantity</u>
<b>ST-004</b>	Petroleum solvent	
<b>NP-008</b>	Cleaning rags	

## D. Access

**524AB, 624AB**

\*\* ON A/C 95074, 95076, 95078–UP

**524BB, 624BB, 524CB, 624CB**

 3. Job Set-Up

## A. Safety Precautions

(1) Obey the wing maintenance and safety precautions (**Ref. Task 57-00-00-920-801**).

## B. Aircraft Maintenance Configuration

EFFECTIVITY: ALL

**57-45-00**

220-802  
 Page 601  
 May 13/19

## RRJ-95 AIRCRAFT MAINTENANCE MANUAL

- (1) Extend the slats fully (**Ref. Task 27-50-00-860-801**).
- (2) Attach the warning tag, which prohibits operation with the flaps/slats control system, on the flap/slat lever on the center pedestal in the flight compartment.
- (3) Open the circuit breakers specified below (**Ref. Task 24-00-00-860-801**):

Distribution box	C/B designation		Remarks
	on distribution box	on wiring diagram	
DB 115V N1	FLAP MACE1	F5-28	
DB 115V N1	SLAT MACE1	F5-29	
DB 115V N2	FLAP MACE2	F6-29	
DB 115V N2	SLAT MACE2	F6-30	

- (4) Attach the warning tag, which prohibits closing of the circuit breakers.

### C. Access

- (1) Install the **GE-06-002** access platform in the work area.  
 \*\* ON A/C 95007–95073, 95077
- (2) Remove the access panels: **524AB, 624AB**.  
 \*\* ON A/C 95074, 95076, 95078–UP
- (3) Remove the access panels: **524AB, 624AB, 524BB, 624BB, 524CB, 624CB**.

## 4. Procedure

### A. (Ref. **Fig. 601**)

Preparation for Inspection

**WARNING:** USE THE SOLUTIONS, CLEANING AGENTS, SEALING COMPOUNDS AND OTHER SPECIAL MATERIALS ONLY WITH SUFFICIENT AIR VENTILATION. OBEY INSTRUCTIONS OF THE MANUFACTURER. THESE MATERIALS ARE TOXIC, FLAMMABLE AND IRRITATE THE SKIN. IN CASE OF SKIN OR EYES IRRITATION, CONSULT A DOCTOR.

- (1) If required, clean the inspected surface by the **NP-008** cleaning rags wetted with **ST-004** solvent.

### B. Detailed Inspection of the Slat Section 4 Tracks 8 and 9

- (1) Inspect the tracks **(1)**. Make sure that there are no mechanical damages (nicks, chips, scratches), attritions, cracks and residual deformations. During inspection pay special attention to the working surfaces of the tracks flanges.

**NOTE:** Permitted wear of the working surfaces of the track flanges under the bearing and support rollers in the form of the smooth groove is not more than 0.2 mm (0.008 in). Permitted wear of the working surfaces of the tracks under the bearing and support rollers in the places, which correspond to the extended and retracted position of the slat, is not more than 0.3 mm (0.01 in).

Do the measurement with the set of feelers 0.05 mm (0.002 in) – 0.3 mm (0.01 in) and the metallic ruler [length is not more than 100 mm (3.93 in)] on the upper and lower track flanges. Measure the gap between the edge of the metal ruler and the wear on the track surface.

Measure the gaps only in the front part of the track in about 20 mm (0.78 in) distance from the contact point of the front lower support rollers. Apply a ruler across the working surface of the track perpendicular to its surface (ref. **Fig. 602**).

- (2) Inspect the links of the tracks **(2)**. Make sure that there are no mechanical damages (nicks, chips, scratches), attritions, cracks and residual deformations.

EFFECTIVITY: ALL

**57-45-00**

220-802  
 Page 602  
 May 13/19

## RRJ-95 AIRCRAFT MAINTENANCE MANUAL

NOTE: If any defects are detected, eliminate them, (*Ref. SRM*).

- (3) Inspect the stop **(4)** installed on the track 8. Make sure that there are no mechanical damages (nicks, chips, scratches, cracks). Make sure that the stop attachment to the track is not loose.

NOTE: If any defects are detected, eliminate them, (*Ref. SRM*).

- (4) Make sure that there are no corrosion damages and defects of the paint coating on the surface of the tracks **(1)**, links **(2)** and stop **(4)**.
- (5) Inspect the visible parts of the bolted and riveted joints. Make sure that they are not loose, are locked with cotter pins, have no corrosion damages and defects of the paint coating.
- (6) Inspect the bearings **(3)**.

NOTES: 1. The bearing breakage and its pushing out is not permitted.

2. If the mechanical damages (nicks, chips, scratches, cracks) is detected, write to the Manufacture.

### 5. Job Close-Up

#### A. Close Access

- (1) Clean the work area, make sure that there are no foreign objects.

\*\* ON A/C 95007–95073, 95077

- (2) Install **524AB**, **624AB** access panels.

\*\* ON A/C 95074, 95076, 95078–UP

- (3) Install **524AB**, **624AB**, **524BB**, **624BB**, **524CB**, **624CB** access panels.

- (4) Remove the access platform.

#### B. Return of the Aircraft to the Initial Configuration

- (1) Remove the warning tag from the flap/slat lever on the central pedestal in the flight compartment.
- (2) Remove the warning tag and close the circuit breakers (*Ref. Task 24-00-00-860-801*):

FLAP MACE1,  
FLAP MACE2,  
SLAT MACE1,  
SLAT MACE2.

- (3) Retract the slats fully (*Ref. Task 27-50-00-860-802*).

**RRJ-95 AIRCRAFT MAINTENANCE MANUAL**

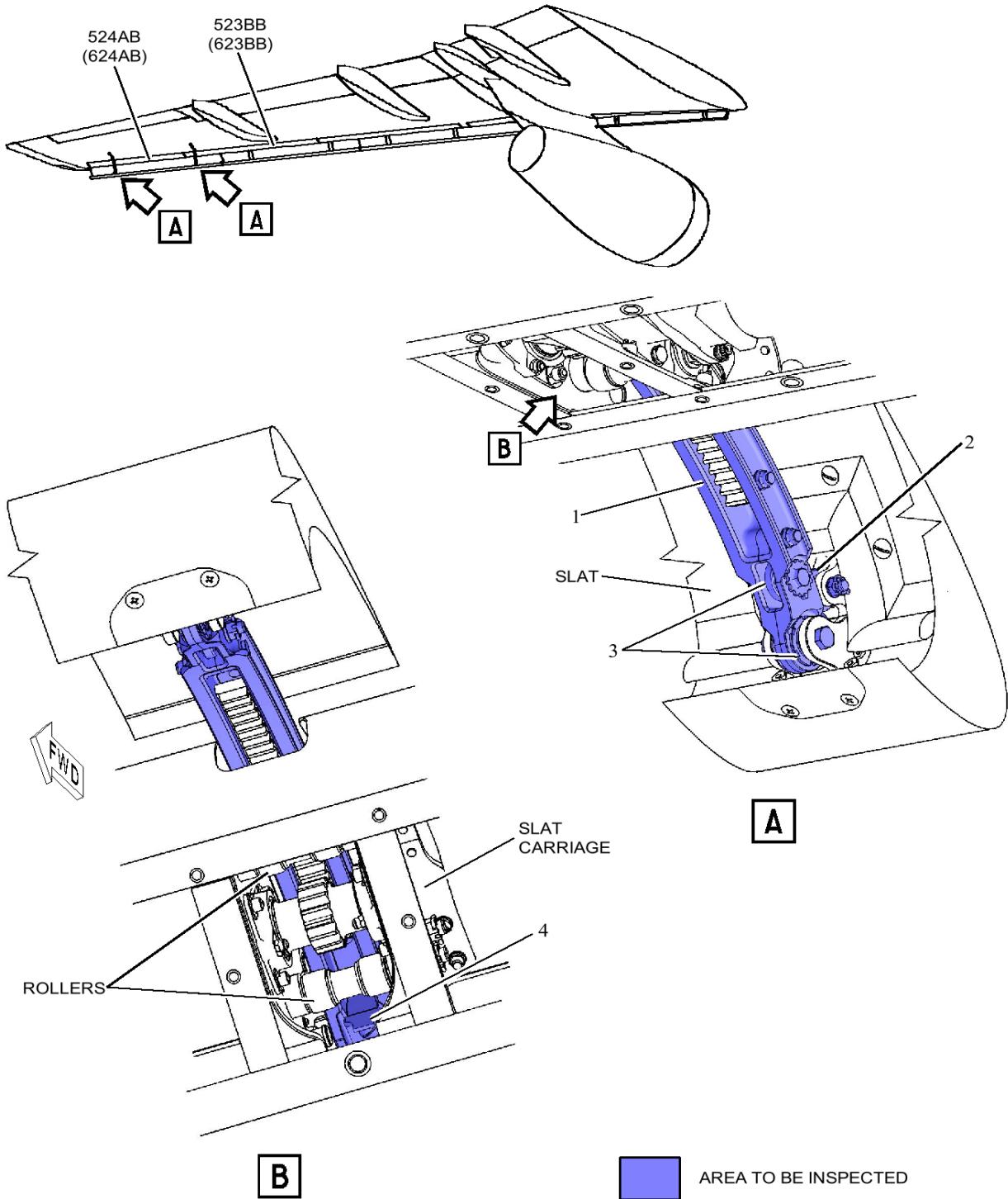

ITK\_RRJ\_AMM\_57\_45\_00\_220\_802\_001\_A01\_E

Detailed Inspection of the Slat Section 4 Tracks 8 and 9  
Figure 601

EFFECTIVITY: ALL

**57-45-00**

220-802  
Page 604  
May 13/19

**RRJ-95 AIRCRAFT MAINTENANCE MANUAL**

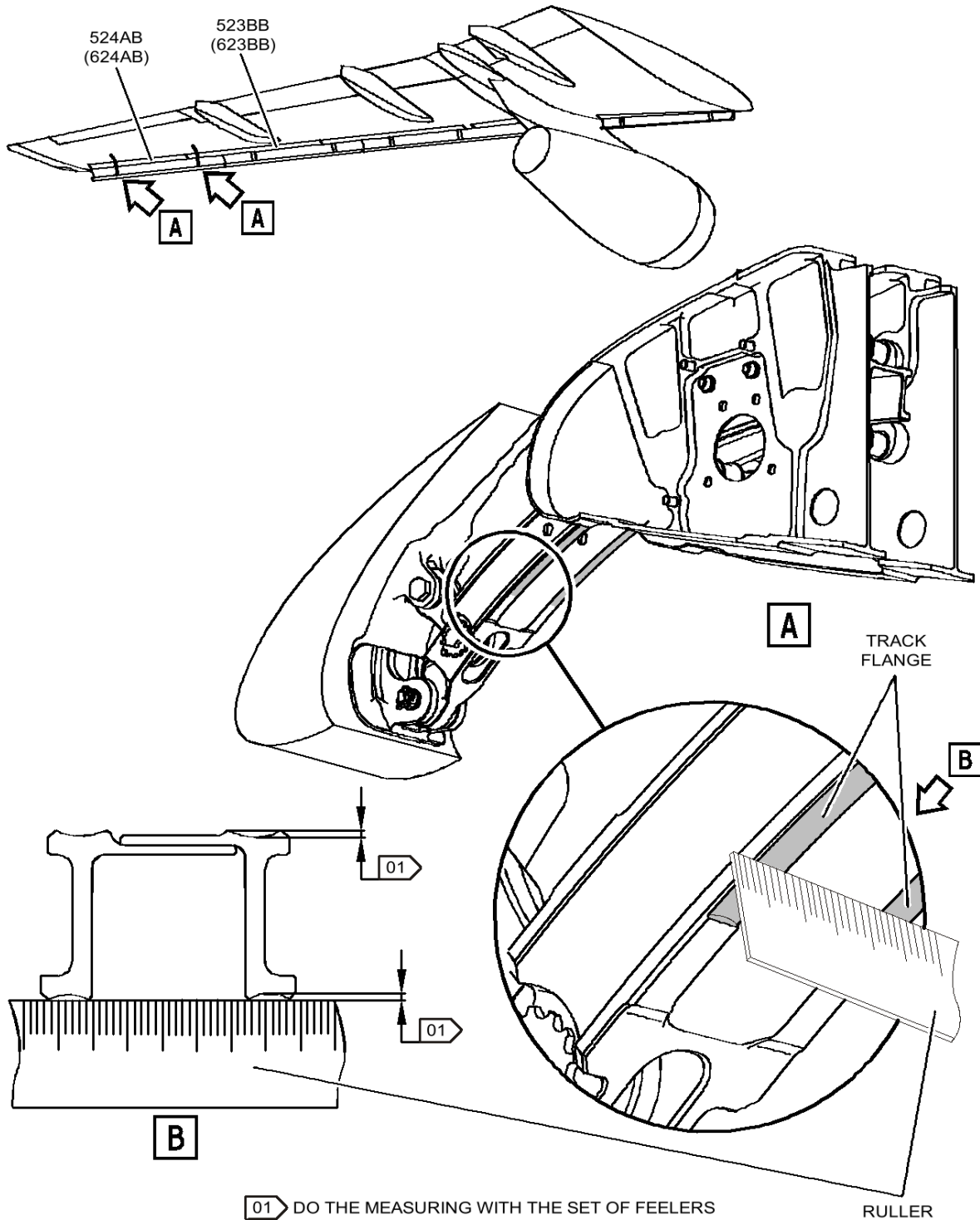

ITK\_RRJ\_AMM\_57\_45\_00\_220\_802\_002\_E

Measuring of the track wear  
Figure 602

EFFECTIVITY: ALL

**INTENTIONALLY LEFT BLANK**

EFFECTIVITY: ALL